

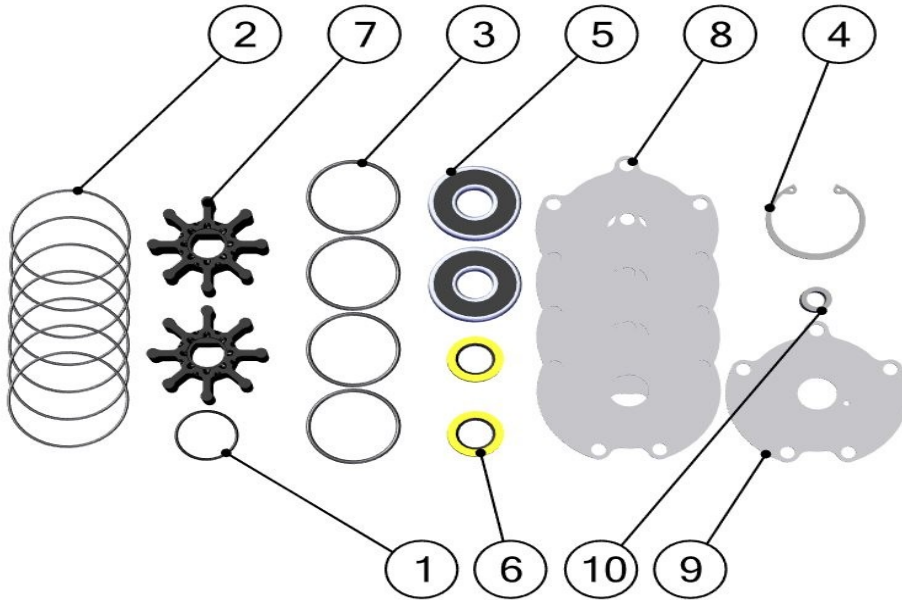

# DUAL STAGE GEN 1 MASTER REBUILD KIT

625-4167



Description	BOM ID	Qty
625-1026	1	1
625-1037	2	7
625-1134	3	4
625-4003	4	1
625-4004	5	2
625-4005	6	2
625-4011	7	2
625-4018	8	4
625-4019	9	1
625-4020	10	1

- **Step 1:**

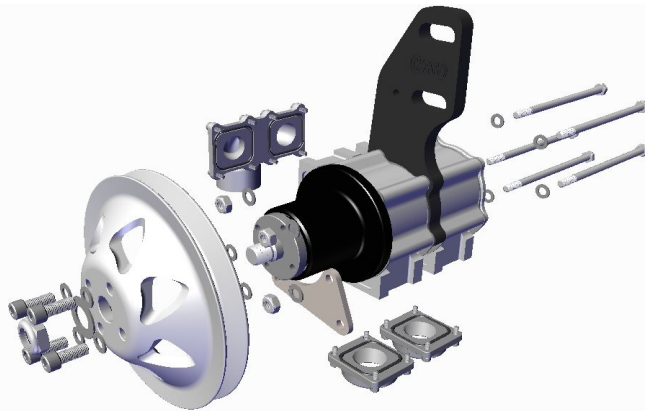

1) Remove sea pump pulley using 15/16 socket and 1/4 hex socket.

2) Remove inlet and outlet adapters using 5/32 allen key.

3) Using 1/2 socket or wrench remove nuts and bolts holding sea pump together.

- **Step 2:**

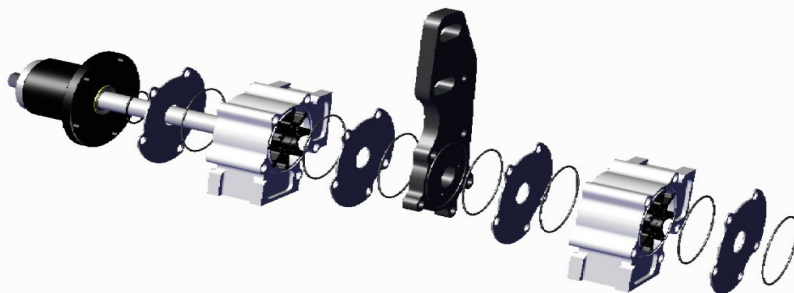

1) Remove the sea pump bracket, body, wear plates and impeller.

2) Discard the impeller, o-rings and wear plates.

3) Inspect and clean body, bracket, rear cover and front snout with shaft.



# DUAL STAGE GEN 1 MASTER REBUILD KIT

625-4167

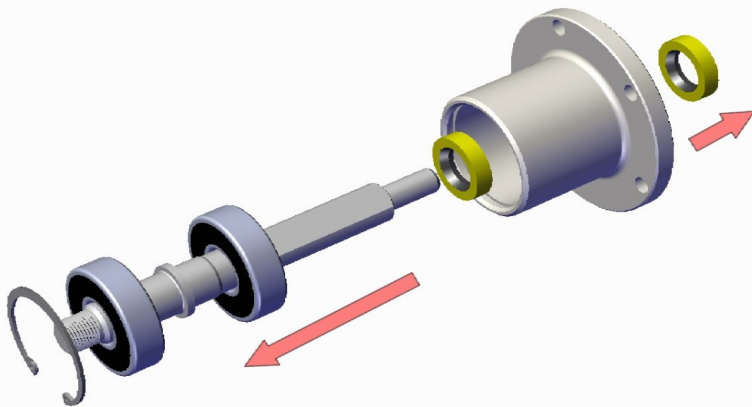

- **Step 3:**
  - 1) Using snap ring pliers, remove snap ring.
  - 2) Slide shaft and bearings out the front. Remove the bearings.
  - 3) Remove the 2 seals.

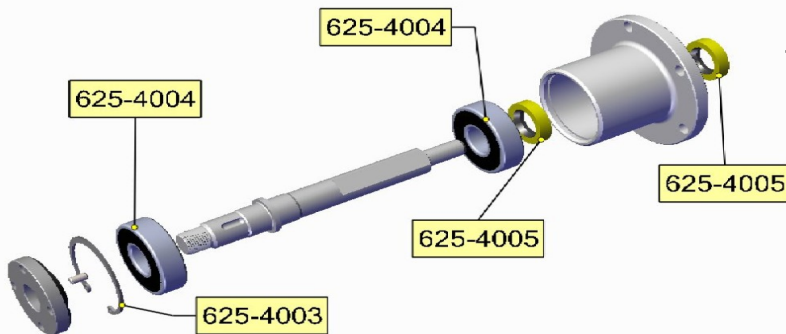

- **Step 4:**
  - 1) These are the replacement parts for the front snout assembly.

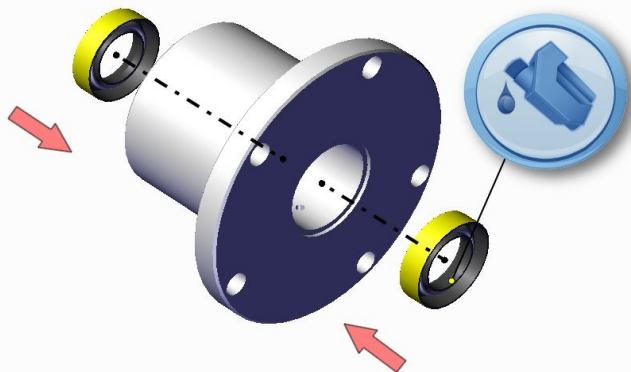

- **Step 5:**
  - 1) Press seals into the housing as shown. Make sure the spring side of the seal is towards the impellers.
  - 2) Make sure the seals are flush with the inside and back side of the bearing housing.
  - 3) Coat seals with petroleum jelly.



# DUAL STAGE GEN 1 MASTER REBUILD KIT

625-4167

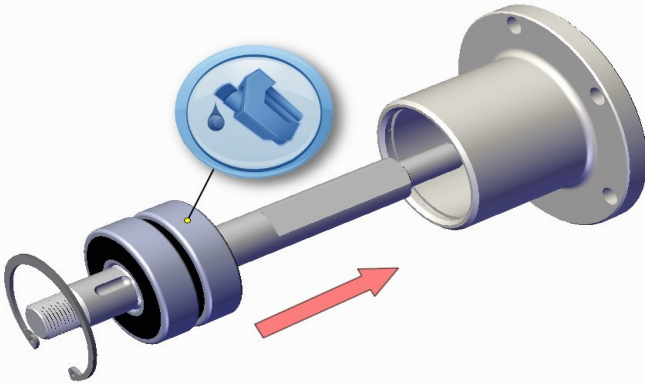

- **Step 6:**

- 1) Coat the outside of the bearings with oil. This will help the shaft assemble slide into the housing.
- 2) Using snap ring pliers, install the snap ring.

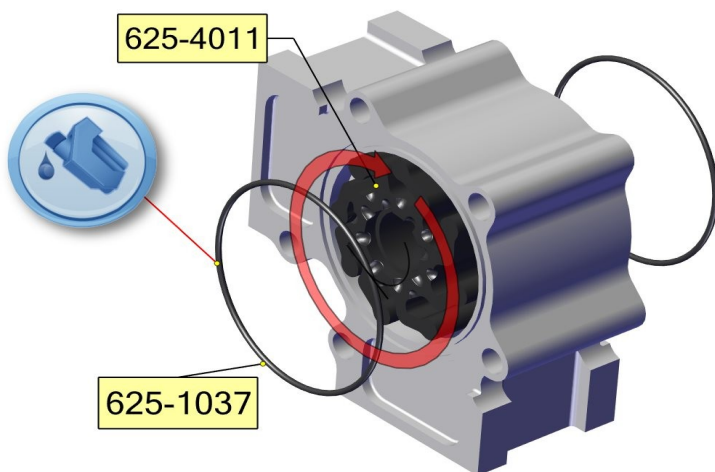

- **Step 7:**

- 1) Apply petroleum jelly to the inside of the sea pump body and to both ends of the impeller.
- 2) Notice the rotation shown. This is for typical port side mounted sea pump standard rotation engine. When installing on to the shaft keep track of which side is front.
- 3) Apply petroleum jelly to both 625-1037 o-rings. Install 1 on each side of the sea pump body.



- **Step 8:**

- 1) Apply petroleum jelly to both 625-1037 o-rings and install into the grooves into the bracket on both sides.



# DUAL STAGE GEN 1 MASTER REBUILD KIT

625-4167

- **Step 9:**

1) Apply petroleum jelly to the small 625-1026 o-ring.

2) Install into the groove around the shaft seal.

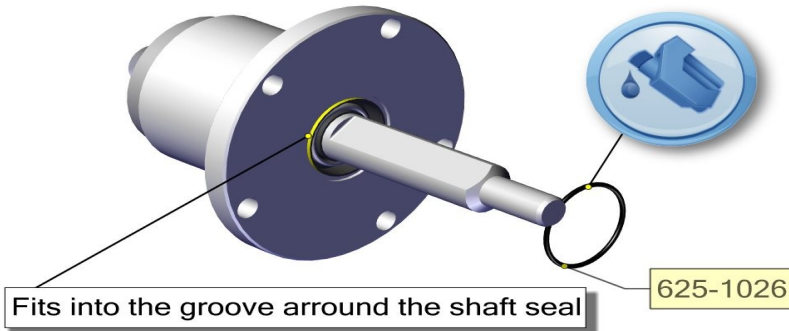

- **Step 10:**

1) Slide the components onto the shaft as shown.

2) Notice 625-4019 wear plate hole position. This is for GEN 1 ONLY.

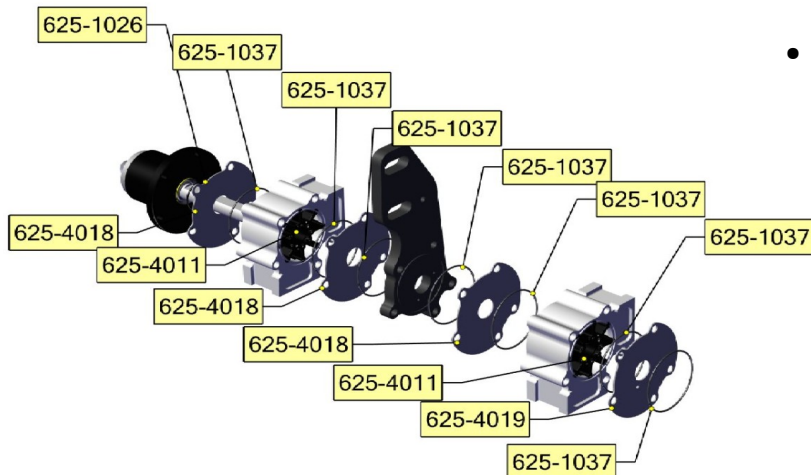

- **Step 11:**

1) Screw 1/2-13 tap into the bushing in the rear cover. When the tap bottoms out, it will pull out the old bushing.

2) Press new bushing back into the rear cover.

3) Coat the bushing with petroleum jelly.

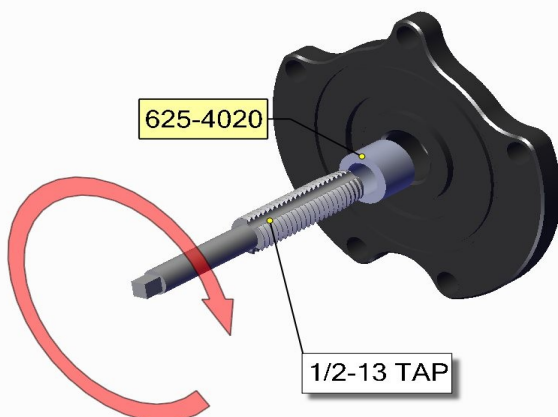



# DUAL STAGE GEN 1 MASTER REBUILD KIT

625-4167

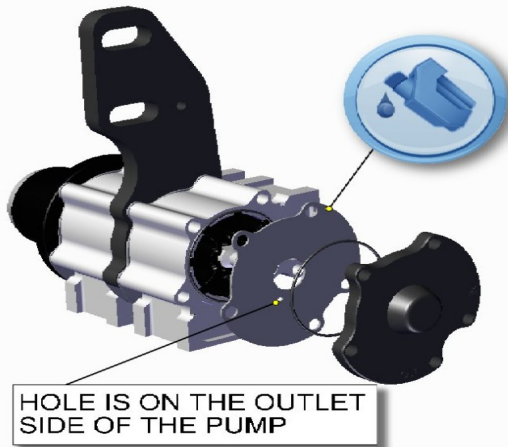

- **Step 12:**

- 1) Apply petroleum jelly to the 625-1037 and install into the groove in the rear cover.
- 2) Apply petroleum jelly to the end of the shaft.
- 3) Install 625-4019 wear plate, notice the hole in the plate position. Install rear cover.



- **Step 13:**

- 1) Install anti-sieze to the bolts.
- 2) Install bolts with washers in from the back side.
- 3) Slide 625-4022 over the bolts.
- 4) Install washers and nuts. Using 1/2 socket torque to 25 ft. lbs..

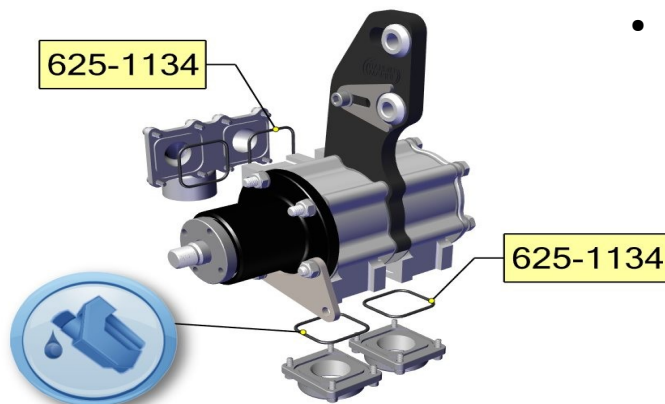

- **Step 14:**

- 1) Using the supplied 625-1134 o-rings install.
- 2) For Stainless bodies, apply anti-sieze to the bolts.
- 3) For Aluminum bodies, apply loctite to the bolts.
- 4) Using 5/32 hex socket, torque to 60 in. lbs..



## DUAL STAGE GEN 1 MASTER REBUILD KIT

625-4167

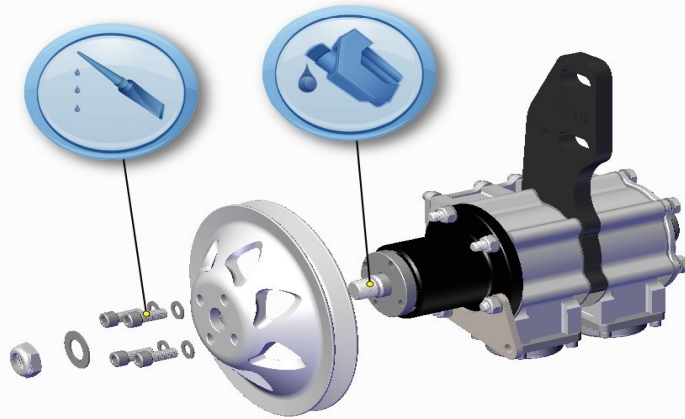

- **Step 15:**

- 1) Apply anti-sieze to the shaft threads. Install pulley.
- 2) Apply loctite to the 5/16 bolts. Using 1/4 socket torque to 25 ft. lbs..
- 3) Install 5/8 nut and washer. Using 15/16 socket torque to 50 ft. lbs..